



- Ⓓ Gebrauchsanweisung
- ⒼⒹ Instructions for use
- Ⓕ Mode d'emploi
- Ⓔ Instrucciones para el uso
- Ⓘ Istruzioni per l'uso

WENKO[®]

25312100



25313100





ⓓ	Gebrauchsanweisung	3
ⓖⓑ	Instructions for use	9
ⓕ	Mode d'emploi	15
ⓔ	Instrucciones para el uso	21
ⓓ	Istruzioni per l'uso	27

Inhaltsverzeichnis

	Hinweis	3
	Lieferumfang	3
	Anbringung	4
	Sicherheitshinweise	7
	Pflegehinweise	7





Hinweis

Das Duschsystem sollte von qualifiziertem Fachpersonal montiert werden oder zumindest durch fachkundige Personen. Fehlerhafte Montage kann Wasserschäden verursachen. Einsatz nur mit Trinkwasser und für den privaten Gebrauch.

Das Duschsystem ist auch für den Einsatz mit Durchlauferhitzern geeignet. Jedoch nicht für den Einsatz bei Niederdruck- Warmwasserbereitern oder drucklosen Speichern.

Empfohlener Betriebsdruck: 0,1–0,5 MPa
Heißwassertemperatur: maximal 60 °C

Nur zur Verwendung in Privataushalten mit einer Raumtemperatur über 0 °C. Niemals Temperaturen von 0 °C oder darunter aussetzen. Bitte lesen Sie vor der Installation die Anleitung sorgfältig durch und Beachten die Hinweise. Bitte bewahren Sie die Anleitung gut auf. Bei Schäden, die durch Nichtbeachtung der Gebrauchsanweisung oder Sicherheitshinweise entstehen, erlischt der Garantieanspruch. Für die Folgeschäden, die darauf resultieren, übernehmen wir keine Haftung. Die Gebrauchsanweisung entspricht dem technischen Stand bei Druck. Änderungen in Technik und Ausstattung sind vorbehalten.

Lieferumfang

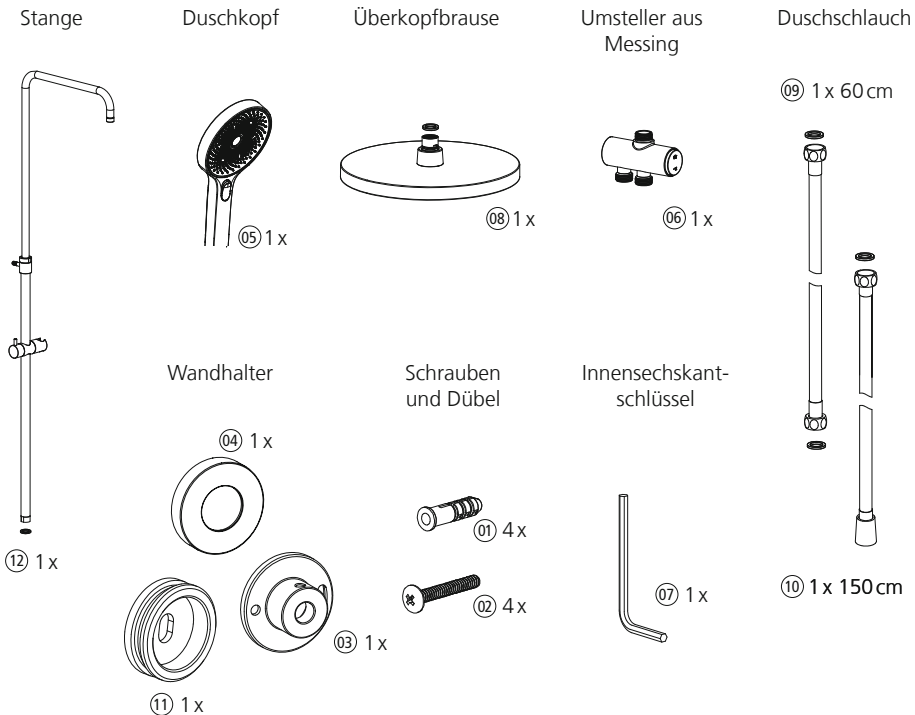



Anbringung

1



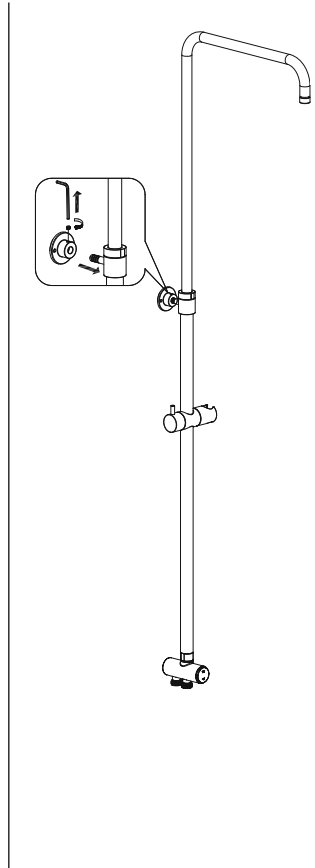
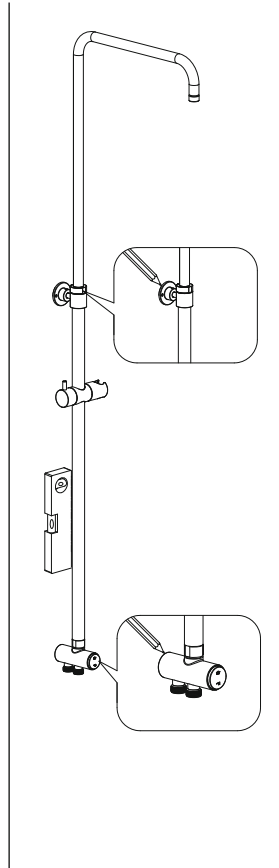
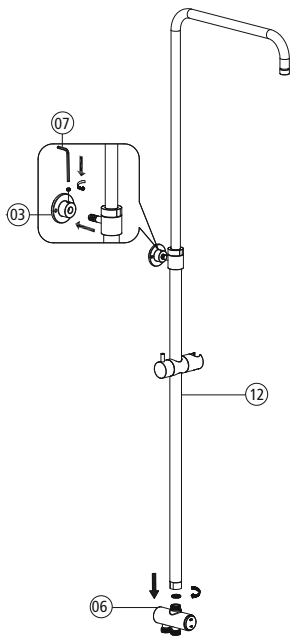
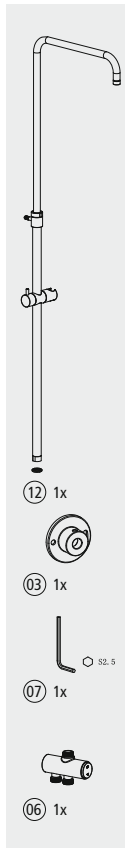

2

3





4

-  01) 3x
-  02) 3x
-  04) 1x
-  11) 1x

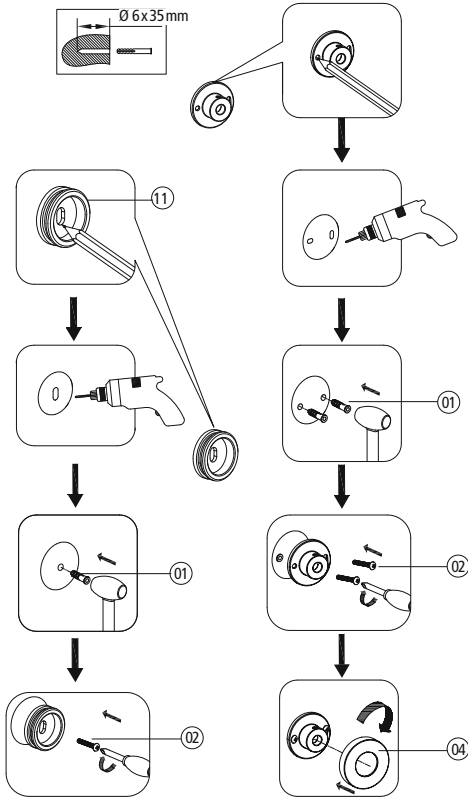

5

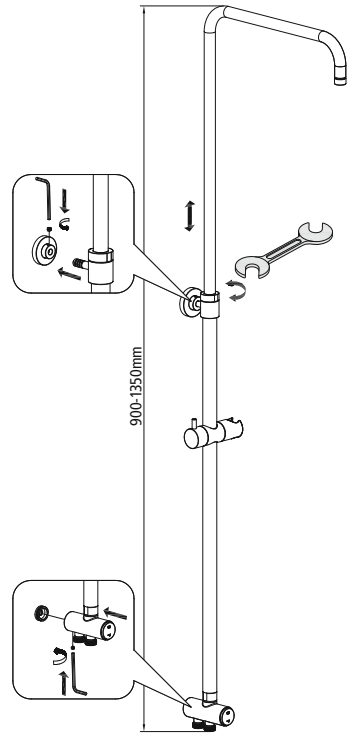



6

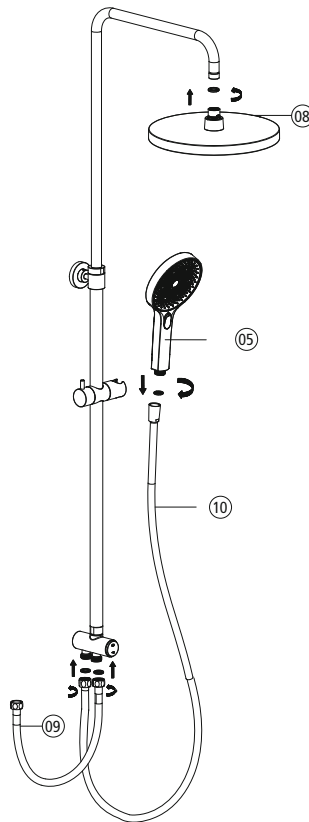



Sicherheitshinweise

Stellen Sie vor Montage die allgemeine Wasserzufuhr ab.

Vergewissern Sie sich vor dem Bohren, dass sich keine elektrischen Leitungen oder Wasserleitungen unter der Bohrstelle befinden. Gefahr vor elektrischem Schlag oder Wasserschaden.

Das beigelegte Montagematerial ist nur für normales, festes Mauerwerk geeignet.

Lassen Sie niemals Kinder mit Verpackungsmaterial spielen – Erstickungsgefahr.

Stellen Sie sicher, dass alle Dichtungen den korrekten Sitz haben. Dichtungen sind Verschleißteile und müssen von Zeit zu Zeit ausgetauscht werden.

Bitte achten Sie vor jedem Gebrauch auf die Einstellung der Wassertemperatur – Verbrühungsgefahr!

Vergewissern Sie sich vor Gebrauch, dass alle Teile unbeschädigt sind und sachgerecht montiert wurden. Überprüfen Sie regelmäßig alle Anschlüsse auf Dichtheit und Unversehrtheit. Bei Undichtigkeit oder Schäden Fachpersonal hinzuziehen.

Keine ätzenden oder korrosiven Mittel mit den Brauseschläuchen in Verbindung bringen – Gefahr vor Wasserschaden.

Wurde das Überkopfbrauseset für eine längere Zeit nicht genutzt, sollte eine größere Wassermenge durchlaufen, bevor das Duschsystem genutzt wird.

Steht das Wasser länger als 4 Stunden seit der letzten Nutzung, lassen Sie es kurz durchlaufen bis deutlich kühleres Wasser austritt. Verwenden Sie kein Stagnationswasser zur Zubereitung von Getränken oder Speisen, insbesondere nicht Säuglings- oder Kindernahrung.

Für Nickelallergiker empfiehlt es sich, kein Stagnationswasser für Ernährung und/oder Körperpflege zu nutzen – Gefahr vor allergische Reaktion.

Pflegehinweise

Bitte trocknen Sie das Duschsystem nach Gebrauch ab. Bitte verwenden Sie nur saubere und weiche Tücher, keine kratzenden Tücher oder Tücher aus Mikrofaser. Bitte nutzen Sie ausschließlich milde Reinigungsmittel, am besten auf Zitronenbasis. Auf keinen Fall Schimmelreiniger oder ähnliches verwenden.

Nach dem Reinigen mit klarem Wasser abspülen und einem sanften Tuch abtrocknen.





Content

Note	9
Includes	9
Mounting	10
Safety instructions	13
Care instructions	13





Note

The shower system should be installed by qualified experts or at least by skilled persons. Incorrect installation may lead to water damage.

Use only with drinking water and for private use. The shower system is also suitable for use with continuous-flow water heaters. Not, however, for use with low-pressure water heaters or unpressurised tanks.

Recommended operating pressure: 0,1–0,5 MPa
Hot water temperature: maximal 60 °C

Only for use in private households at a room temperature above 0°C. Never expose to temperatures of 0°C or below. Please read the information carefully prior to installation and follow the instructions. Please keep the instructions available for future reference. The guarantee becomes null and void in the case of damage caused by non-observance of the instructions for use or the safety instructions. We shall not assume any liability for damage resulting as a consequence thereof. The instructions for use comply with the technical status at the time of printing. We reserve the right to make modifications in technology and equipment.

Includes

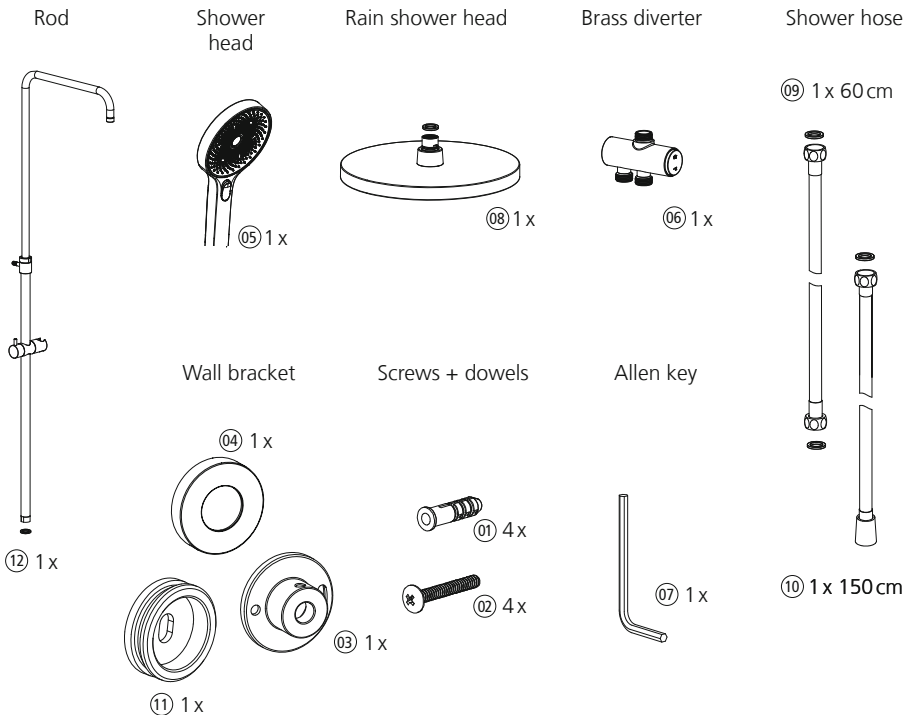



Mounting

1



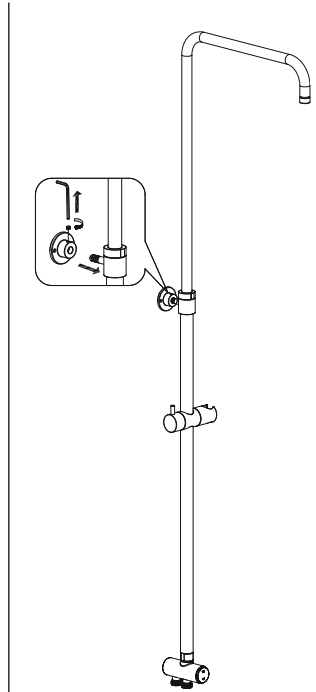
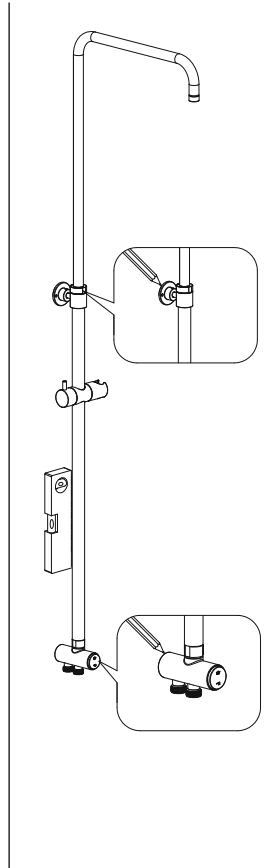
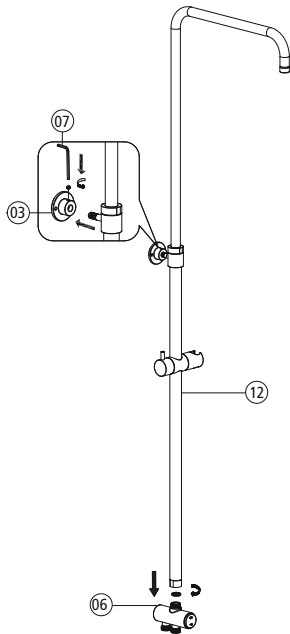
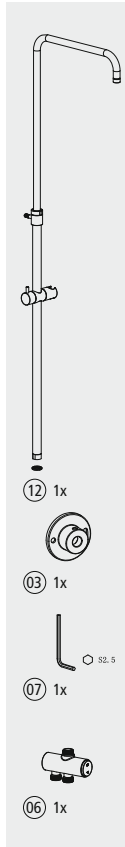

2

3





4

-  01) 3x
-  02) 3x
-  04) 1x
-  11) 1x

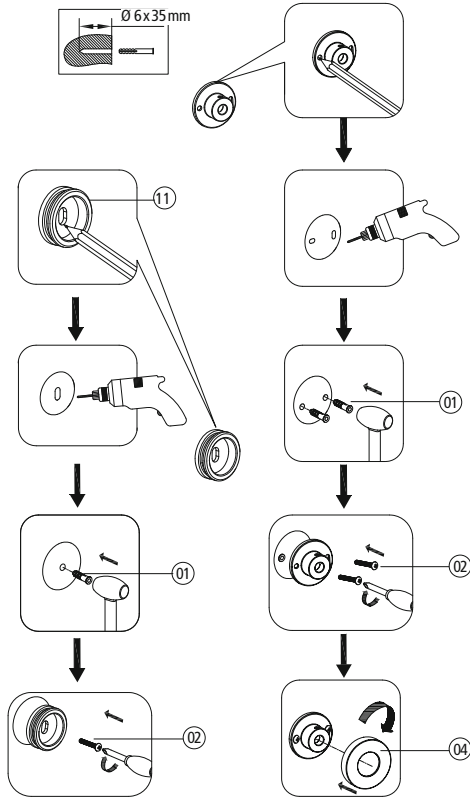

5

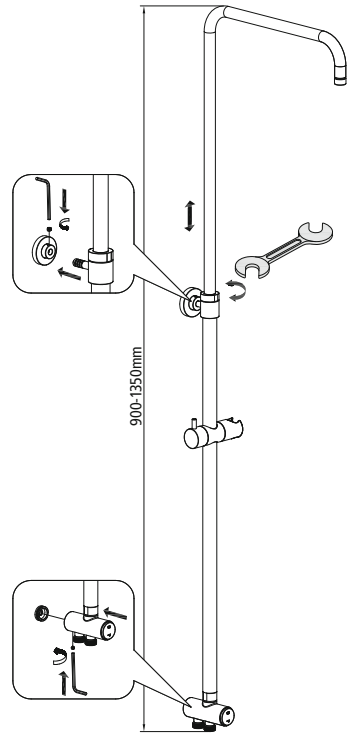



6

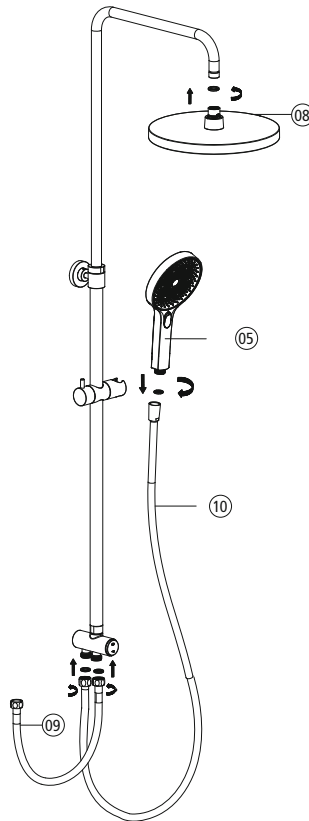



Safety instructions

Disconnect the general water supply prior to installation.

Before commencing any drilling work, please make sure that there are no electrical cables or water pipes underneath the drilling point. Risk of electric shock or water damage.

The enclosed mounting material is only suitable for normal, solid masonry.

Never allow children to play with packaging material – risk of suffocation.

Make sure that all seals fit correctly. Seals are subject to wear and must be replaced from time to time.

Before each use, please check the water temperature setting - risk of scalding.

Before use, please check that all parts are undamaged and have been mounted properly. Check all connections regularly for leak tightness and intactness. In case of any leaks or damage, consult a qualified expert.

Ensure that the shower hoses do not come into contact with caustic or corrosive agents – risk of water damage.

If the overhead shower set is not in use for a longer period of time, allow a larger amount of water to run through the system before using it again.

If the water has been standing for longer than 4 hours after the last use, allow it to run until noticeably cooler water is discharged. Do not use stagnated water to prepare drinks or food, particularly not for babies and infants.

Do not use stagnated water for nutrition or personal hygiene for persons allergic to nickel - risk of allergic reactions.

Care instructions

Please dry the shower system after use. Please only use clean and soft cloths, not cloths that may scratch or microfibre cloths. Please only use mild, preferably citric acid-based cleaning agents. Do not under any circumstances use mould removers.

Rinse with clear water after cleaning and dry with a soft cloth.

Mount according to installation drawings.



Contenu

Information	15
Étendue de la livraison	15
Montage	16
Consignes de sécurité	19
Indications pour l'entretien	19



Information

Le système de douche doit être monté par un personnel technique qualifié ou au moins par des personnes compétentes. Un montage incorrect peut occasionner des dégâts d'eau. Utilisation uniquement avec de l'eau potable et pour un usage privé. Le système de douche est également approprié pour les chauffe-eau instantanés. Mais pas pour l'utilisation avec des chauffe-eau à basse pression ou des accumulateurs non pressurisés.

Pression de service recommandée : 0,1–0,5 MPa
Pression de service recommandée : maximal 60 °C

À utiliser uniquement dans les ménages privés où la température ambiante est supérieure à 0 °C. Ne jamais exposer à des températures de 0 °C ou moins. Avant de procéder à l'installation, veuillez lire attentivement les instructions et tenir compte des informations. Conservez bien les présentes instructions. Tout dommage causé par le non-respect du mode d'emploi ou des consignes de sécurité entraîne la déchéance de la garantie. Nous déclinons toute responsabilité pour les dommages consécutifs qui pourront en résulter. Le mode d'emploi correspond à l'état de la technique à la date de l'impression. Sous toutes réserves de modifications techniques et des fonctionnalités.

Étendue de la livraison

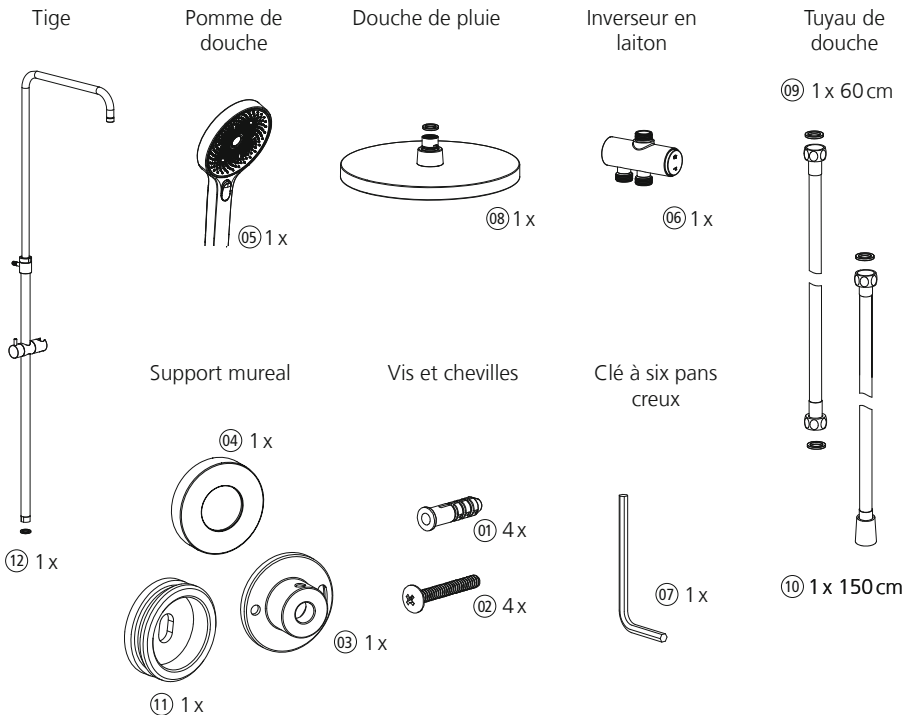



Montage

1

2

3

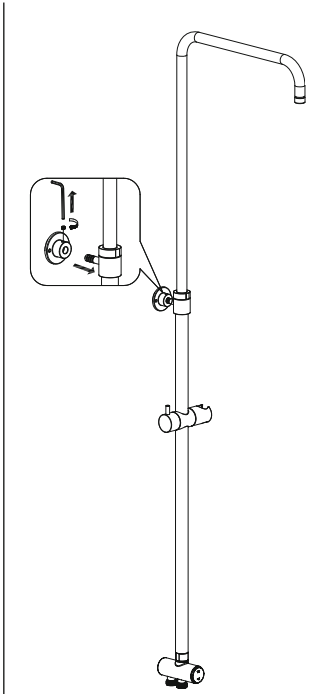
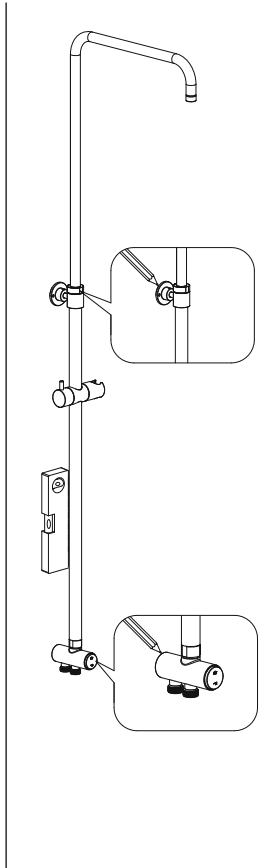
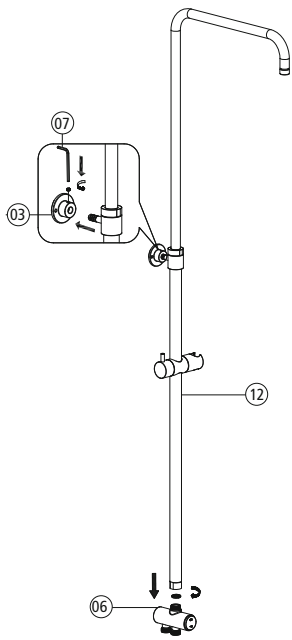
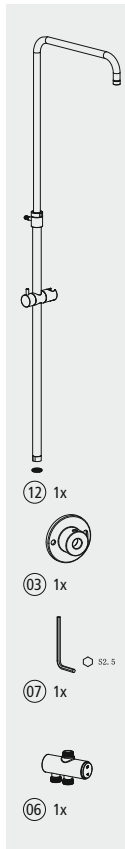



4

-  01) 3x
-  02) 3x
-  04) 1x
-  11) 1x

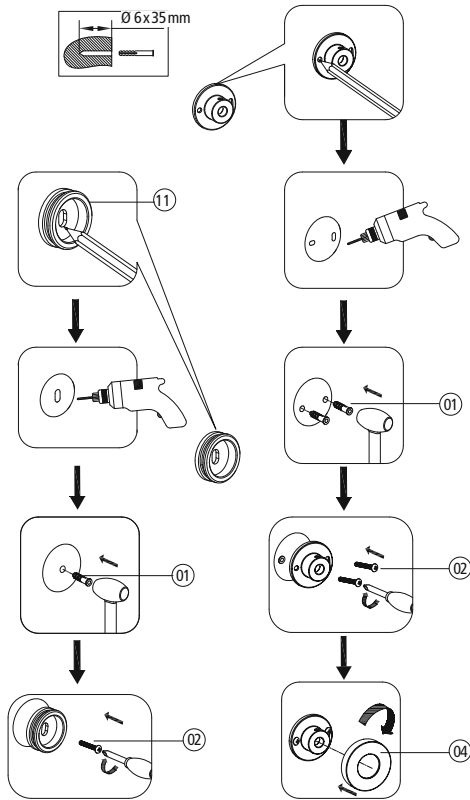

5

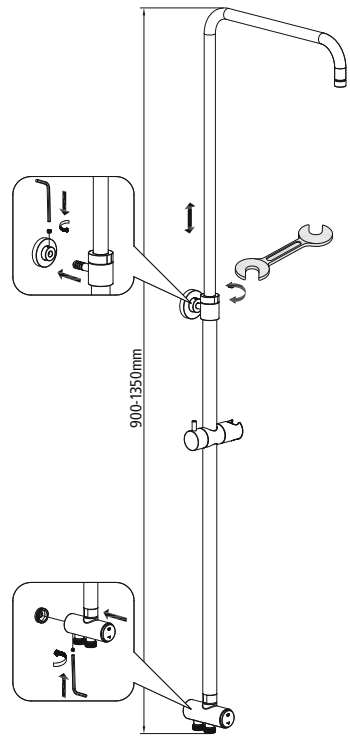



6

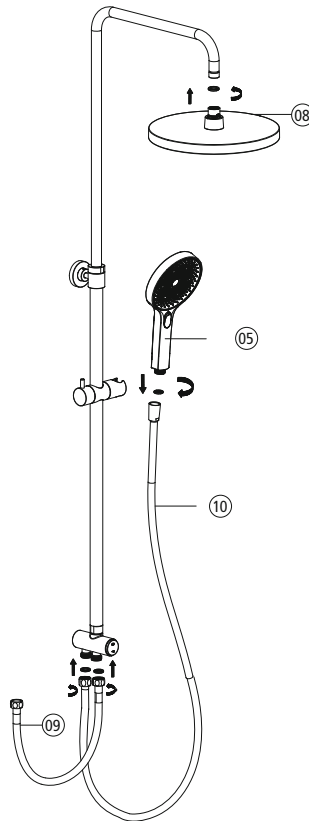
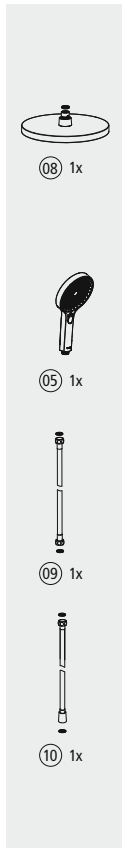



Consignes de sécurité

Avant le montage, coupez l'alimentation générale en eau.

Avant de percer les trous, assurez-vous qu'il n'y a pas de câbles électriques ou de conduites d'eau sous les points de perçage. Risque de choc électrique ou de dégâts des eaux.

Le matériel de montage fourni ne convient que pour une maçonnerie normale et solide.

Ne laissez jamais les enfants jouer avec le matériel d'emballage - risque de suffocation.

Assurez-vous que tous les joints sont correctement logés. Les joints sont des pièces d'usure et doivent être remplacés de temps en temps.

Avant chaque utilisation, vérifiez le réglage de la température de l'eau - risque de brûlure !

Avant l'utilisation, assurez-vous que toutes les pièces sont exemptes de dommages et qu'elles ont été montées convenablement. Vérifiez régulièrement l'étanchéité et l'intégrité de tous les raccords. En cas de défaut d'étanchéité ou de dommage, faire appel à un personnel technique qualifié.

Ne pas mettre de produits corrosifs ou caustiques en contact avec les tuyaux de douche - risque de dégâts des eaux.

Si le set de pommeau de douche à effet pluie n'a pas été utilisé pendant longtemps, il convient de faire couler un volume d'eau relativement important avant d'utiliser le système de douche. Si l'eau a stagné pendant plus de 4 heures depuis la dernière utilisation, faites-la couler brièvement jusqu'à ce que de l'eau nettement plus fraîche en sorte. N'utilisez pas d'eau de stagnation pour préparer des boissons ou des aliments, en particulier des aliments pour nourrissons ou enfants.

Pour les personnes allergiques au nickel, il est recommandé de ne pas utiliser d'eau de stagnation pour l'alimentation et/ou les soins corporels - risque de réaction allergique."

Indications pour l'entretien

Veuillez sécher le système de douche après l'utilisation. Veuillez utiliser exclusivement des chiffons propres et doux, pas de chiffons abrasifs ni de chiffons en microfibres. Utiliser exclusivement des produits de nettoyage doux, de préférence à base de citron. N'utiliser en aucun cas des nettoyeurs anti-moisissure ou des détergers similaires. Après le nettoyage, rincez à l'eau propre et séchez avec un chiffon doux.

Insérer ensuite les dessins Montage.



Contenido

Hinweis	21
Lieferumfang	21
Montaje	22
Indicaciones para la seguridad	25
Indicaciones para el cuidado	25



Indicación

El sistema de ducha debe ser instalado por personal cualificado o, al menos, por personas competentes en la materia. Una instalación incorrecta puede causar daños por agua. Utilizar sólo con agua potable y para uso privado. El sistema de ducha también se puede utilizar con calentadores de agua de paso continuo. Sin embargo, no se puede utilizar con calentadores de agua de baja presión o tanques de almacenamiento sin presión.

Presión de servicio recomendada: 0,1–0,5 MPa
Temperatura del agua caliente: maximal 60 °C

Sólo para uso en hogares con una temperatura ambiente superior a 0°C. No exponer nunca a temperaturas de 0°C o inferiores. Lea atentamente las instrucciones antes de la instalación y tenga en cuenta las indicaciones. Por favor, guarde las instrucciones en un lugar seguro. Cualquier daño causado por el incumplimiento de las instrucciones de uso o de seguridad anulará el derecho de garantía. No asumimos ninguna responsabilidad por cualquier daño resultante de ello. Las instrucciones de uso corresponden al estado actual de la tecnología en el momento de la impresión. Nos reservamos el derecho de hacer cambios en la tecnología y en el equipo.

Volumen de suministro

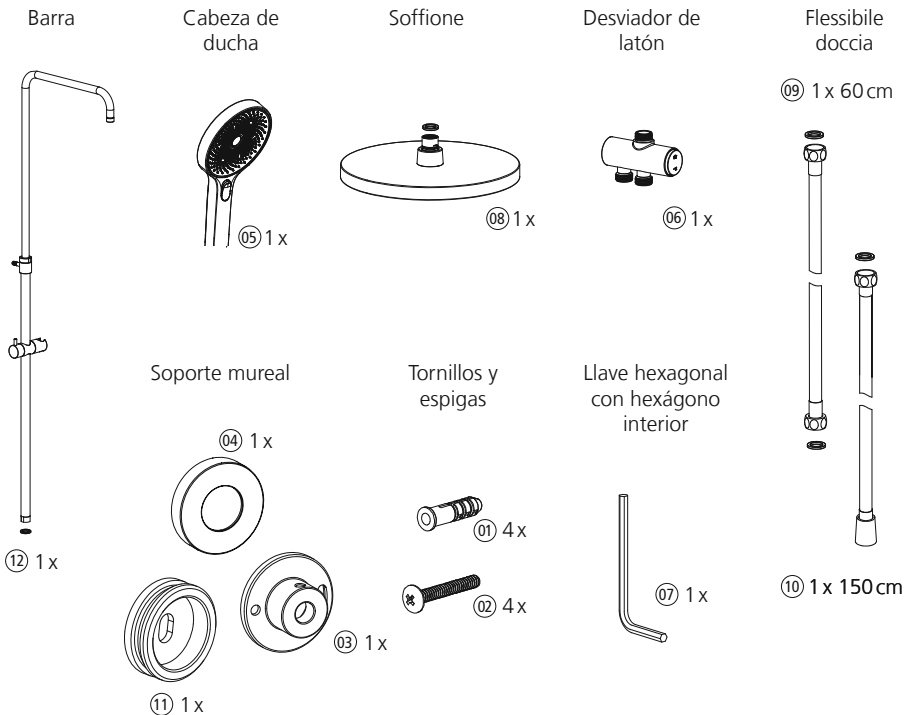



Montage

1

2

3

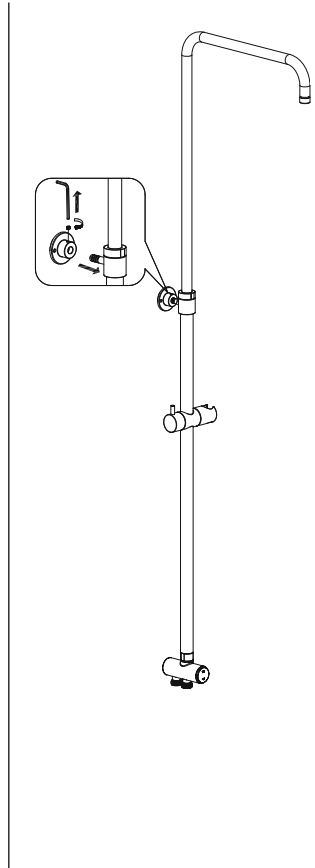
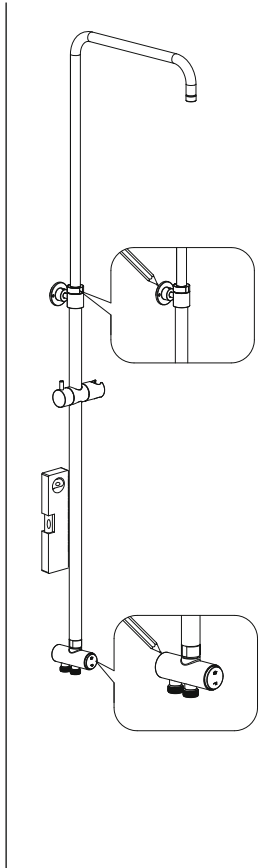
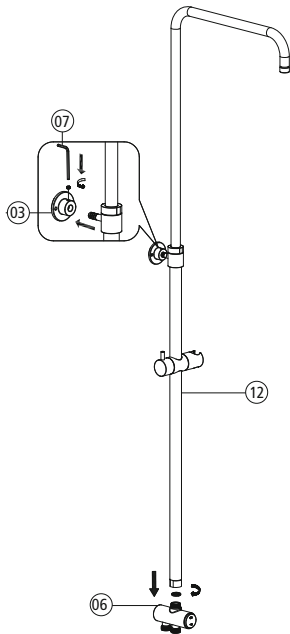
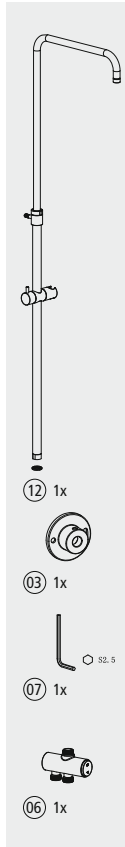



4

-  01) 3x
-  02) 3x
-  04) 1x
-  11) 1x

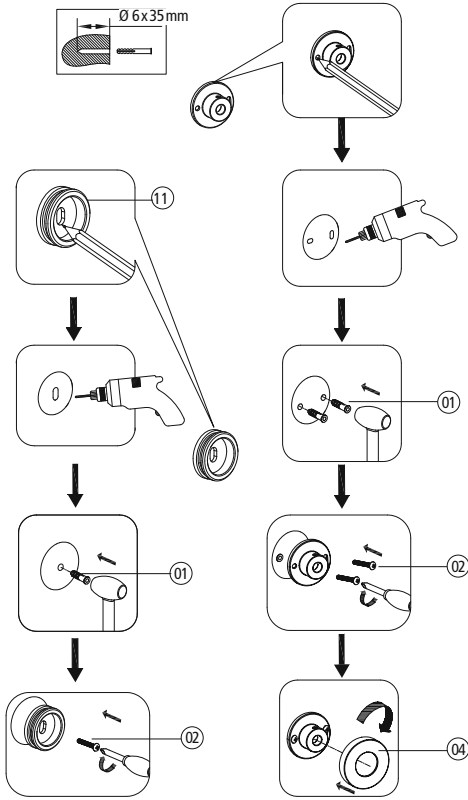

5

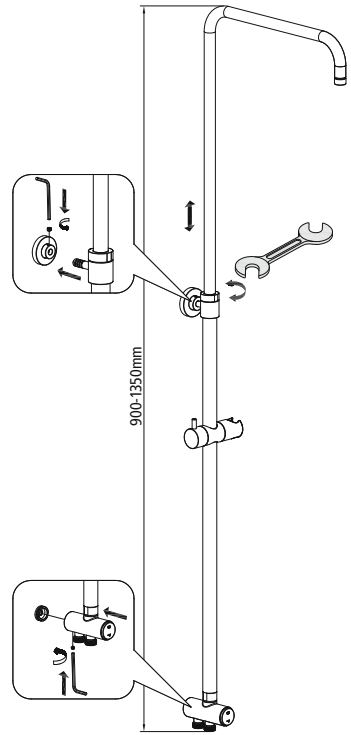



6

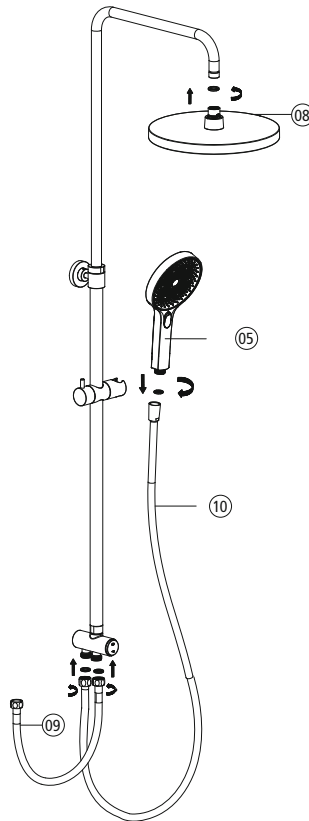
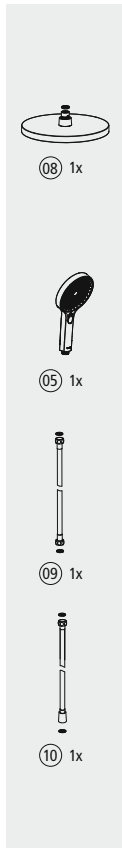



Indicaciones para la seguridad

Cierre el suministro general de agua antes del montaje.

Antes de taladrar, asegúrese de que no haya cables eléctricos ni tuberías de agua bajo el lugar de la perforación. Peligro de descarga eléctrica o daños por agua.

El material de montaje adjunto sólo es adecuado para la mampostería normal y sólida.

No deje que los niños jueguen con el material de embalaje: peligro de asfixia.

Asegúrese de que todas las juntas estén correctamente asentadas. Las juntas son piezas de desgaste y deben ser sustituidas de vez en cuando.

Por favor, asegúrese de que la temperatura del agua esté ajustada antes de cada uso - ¡riesgo de quemaduras!

Antes de utilizarlo, asegúrese de que todas las piezas estén intactas y se hayan montado correctamente. Compruebe regularmente la estanqueidad e integridad de todas las conexiones. En caso de fugas o daños, recurra a personal cualificado.

No ponga en contacto las mangueras de la ducha con agentes corrosivos o cáusticos - riesgo de daños por el agua.

Si el juego de ducha de techo no se ha utilizado durante un período de tiempo prolongado, deberá correr una mayor cantidad de agua antes de utilizar el sistema de ducha.

Si el agua ha estado parada más de 4 horas desde la última vez que se utilizó, déjela correr brevemente hasta que salga agua bastante más fría. No utilice agua estancada para preparar bebidas o alimentos, especialmente si se trata de alimentos para bebés o niños.

Para las personas alérgicas al níquel, se recomienda no utilizar el agua estancada para la alimentación y/o la higiene personal - riesgo de reacción alérgica.

Indicaciones para el cuidado

Por favor, seque el sistema de ducha después de su uso. Por favor, use sólo paños limpios y suaves, no paños ásperos o paños hechos de microfibra. Por favor, use exclusivamente detergentes suaves, de preferencia a base de limón. Bajo ninguna circunstancia utilice detergentes para moho o similares.

Después de limpiar, enjuagar con agua limpia y secar con un paño suave.

A continuación, coloque el conjunto de planos para el montaje.



Contenuto

Avvertenze	27
Entità della fornitura	27
Fissaggio	28
Indicazioni di sicurezza	31
Indicazioni per una corretta manutenzione	31



Avvertenze

Il sistema doccia deve essere montato da personale qualificato o per lo meno da persone esperte e competenti. Un'installazione errata può causare danni provocati dall'acqua.
Utilizzo solo con acqua potabile e in ambito privato. Il sistema doccia è anche adatto per l'impiego con caldaie istantanee. Tuttavia non è indicato per l'utilizzo in presenza di boiler a bassa o senza pressione.

Pressione d'esercizio consigliata: 0,1–0,5 MPa
Temperatura massima acqua calda: maximal 60 °C

Adatto solamente per l'impiego in ambito privato ad una temperatura ambiente superiore ai 0°C. Non esporre mai a temperature pari o inferiori a 0°C. Prima dell'installazione si prega di leggere attentamente le istruzioni e di seguire le indicazioni riportate. Si prega di conservare con cura il manuale di istruzioni. In caso di danneggiamenti risalenti al mancato rispetto delle istruzioni d'uso o delle indicazioni sulla sicurezza, si invalida il diritto di garanzia. Non ci assumiamo alcuna responsabilità in caso di eventuali danni che ne derivano conseguentemente. Le istruzioni d'uso corrispondono allo stato tecnologico attuale al momento della stampa. Con riserva di modifiche tecniche e di dotazione.

Entità della fornitura

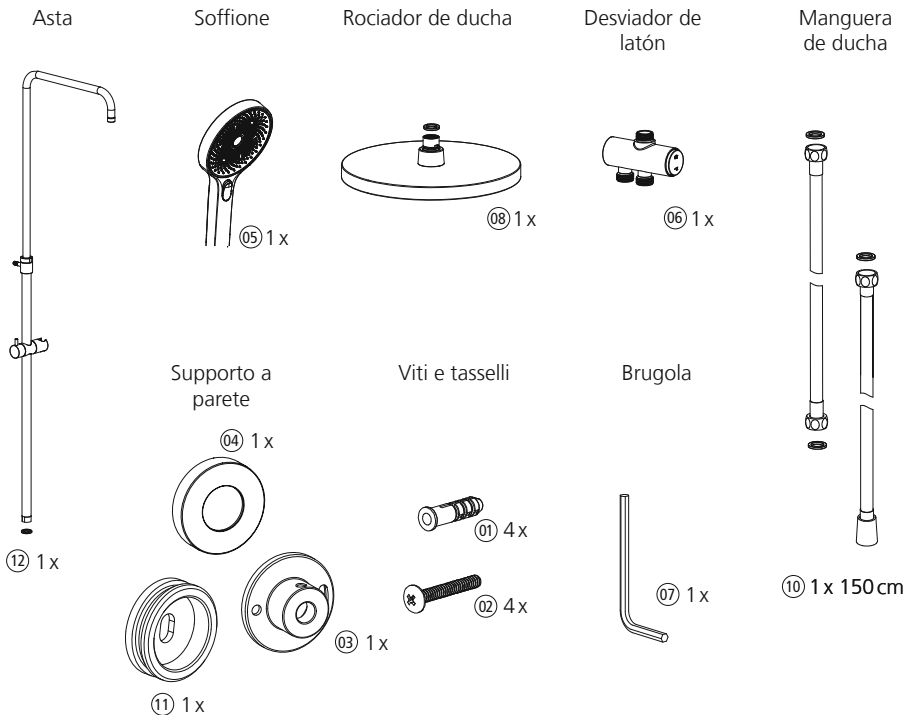



Fissaggio

1

2

3

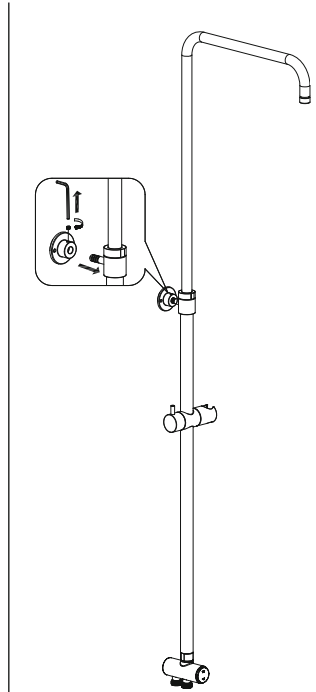
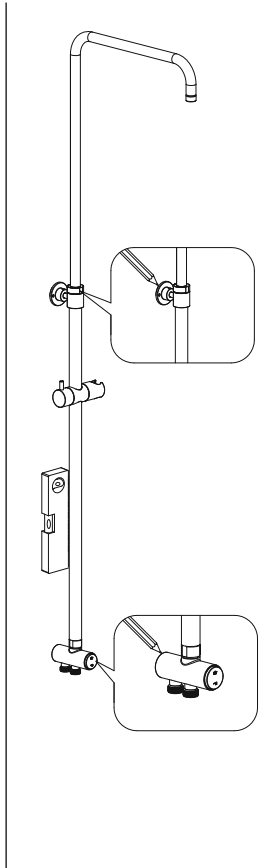
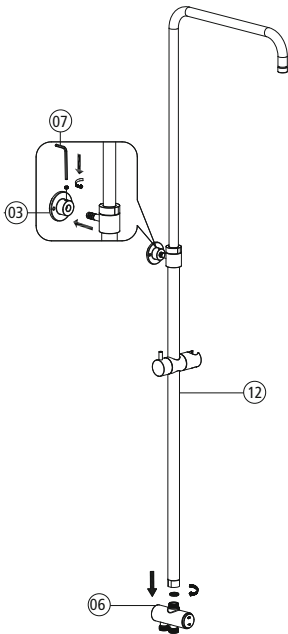
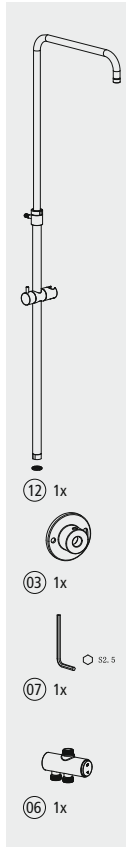



4

-  01) 3x
-  02) 3x
-  04) 1x
-  11) 1x

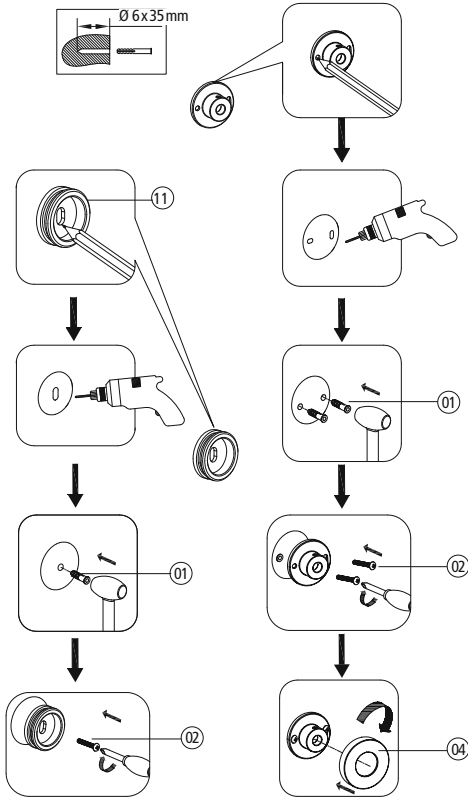

5

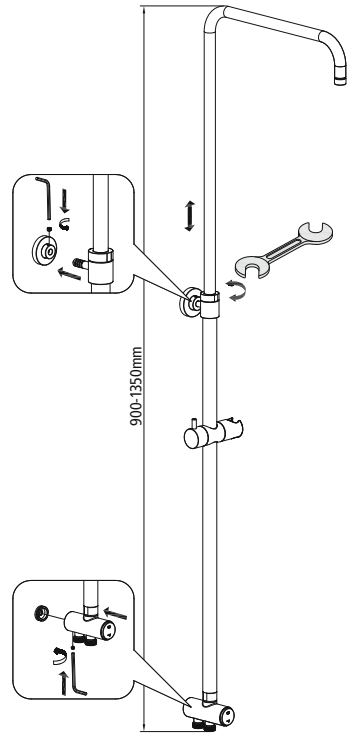



6

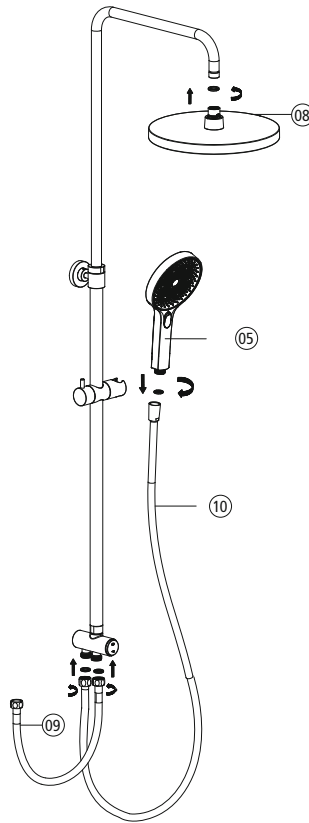
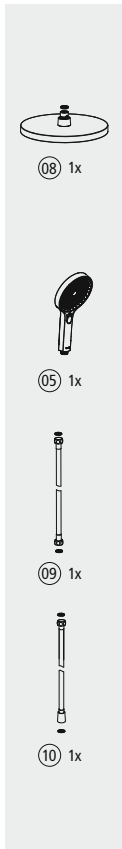



Indicazioni di sicurezza

prima di procedere all'installazione, chiudere la valvola centrale di erogazione dell'acqua.

Prima di procedere alla foratura con il trapano, accertarsi che nel punto da forare non passino cavi elettrici o tubature dell'acqua. Pericolo di scossa elettrica o danni causati dalla fuoriuscita di acqua.

Il materiale di montaggio fornito in dotazione è adatto per normali superfici in muratura solida. Non permettere mai ai bambini di giocare con il materiale di imballaggio - Rischio di soffocamento.

Accertarsi che tutte le guarnizioni siano correttamente installate. Le guarnizioni sono parti soggette all'usura e devono venire sostituite periodicamente.

Prima di ogni utilizzo si prega di prestare attenzione alla regolazione della temperatura dell'acqua - Rischio di ustione!

Prima dell'utilizzo accertarsi che tutte le componenti siano intatte e siano state opportunamente montate. Controllare regolarmente la tenuta e l'integrità di tutti gli allacci. In caso di perdite o danni, consultare personale qualificato.

Non mettere in contatto i tubi flessibili delle doccette con detergenti irritanti o corrosivi - Rischio di danni provocati da perdite di acqua.

Nel caso in cui la colonna doccia non venga utilizzata per lungo tempo, è necessario far scorrere una maggiore quantità di acqua prima di riutilizzare il sistema doccia.

Nel caso in cui siano trascorse più di 4 ore dall'ultimo impiego, lasciare scorrere brevemente l'acqua finché la temperatura risulta chiaramente più fredda. Non utilizzare acqua stagnante per la preparazione di cibi o bevande, in particolare se sono destinati all'alimentazione di neonati o bambini.

Alle persone affette da allergia al nichel si consiglia di non utilizzare acqua stagnante per l'alimentazione e/o la cura del corpo - Rischio di reazioni allergiche.

Indicazioni per una corretta manutenzione

Dopo l'utilizzo asciugare il sistema doccia. Utilizzare solo panni puliti e morbidi, evitare panni abrasivi o in microfibra. Impiegare esclusivamente detergenti delicati, preferibilmente a base di limone. Non impiegare in nessun modo detergenti antimuffa o simili. Dopo la detersione sciacquare con acqua pulita ed asciugare con un panno morbido.

Dopodiché eseguire il montaggio come illustrato.





Wenko-Wenselaar GmbH & Co. KG · Im Hülsenfeld 10 · D-40721 Hilden
Phone +49 2103 573-0 · Fax +49 2103 573-190 · www.wenko.com © 12/2021 WENKO®

25310100 · 25311100 · MA · 260422

